

New

Bulletin 1515 10/02

GSI - E/IFI

Enhanced / Intelligent Field Interface

The **NEW** GSI-E/IFI "Enhanced - Intelligent Field Interface" provides multiple integration solutions for tank gauging.

Designed to be used either in the control room or in the tank farm, the E/IFI is modular in design. The E/IFI can be thought as the Erector Set, Tinker Toys, Building Blocks, or Lego's of the tank-gauging world. It provides connectivity between all local or remote technologies, topologies, and the HMI.

The E/IFI can serve the following functions: 1) Multiple Loop Interface, 2) Protocol Converter, 3) Data Concentrator, 4) Cabling Topology Converter, 5) Remote Terminal Unit, 6) Local Display, and 7) Field (Report) Printer.

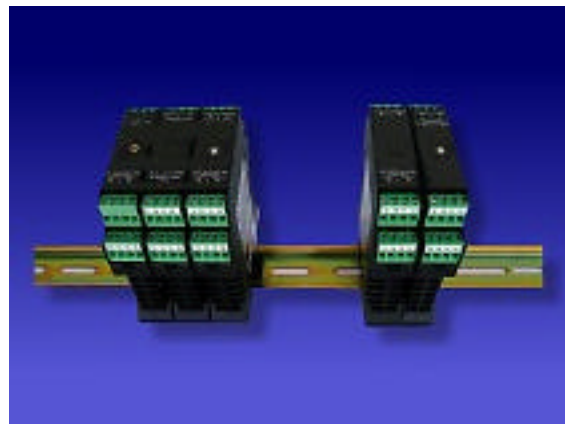

The E/IFI can be used with most cabling topologies (10BASE-FL, Radio, Hardwire, etc.) for host communications and with multiple gauge manufacturers (electrical standards and protocols) at the same time.

Components:

A **CPU module (CPU)** is combined with single or multiple **Intelligent Personality Modules (IPM)**, **Surge Protection Modules (SPM)**, and **Power Supply Modules (PSM)**. All components are Din Rail mounted and housed within a NEMA 4x weatherproof enclosure. **Optional Modules** include: Spread Spectrum Radio, Ethernet Modem, Satellite transceiver, and I/O modules.

The **CPU Module** is the same CPU Board that has been field proven for two years within the E/TGI. It provides a minimum of 2MB of non-volatile (Flash) memory, 16MB RAM, two Ethernet ports (10BASE-FL Fiber Link or 10BASE-T), and two serial ports (RS 232 / RS 485 configurable).

The E/IFI operating software comes complete with a WEB browser and can be used as a WEB enabled device. It can be custom programmed for special applications, with options for a ribbon



Gauging Systems Inc.
910 Industrial Blvd. • Suite A
Sugar Land • Texas • 77478
Phone: (281) 980-3999 Toll Free: 800-444-1327
Fax: (281) 980-6929 E-mail: gsihoutx@msn.com
[Http://www.gaugingsystemsinc.com](http://www.gaugingsystemsinc.com)

printer and local display.

One port on the **CPU Module** is used for a communications bus (RS 485) to the **Intelligent Personality Module** or multiple **Intelligent Personality Modules**. Each **CPU Module** can address up to thirty-two (32) **Intelligent Personality Modules**.

Each **Intelligent Personality Module** can have a different protocol and / or electrical standard. This is solely based upon the electrical standard and protocol of the gauge type used within that wiring loop. Multiple cabling loops can utilize the same or different types of **Intelligent Personality Modules**. A fiber port is also provided on the IPM for diagnostics or communications to the CPU.

Within each **Intelligent Personality Module** there is a **Surge Protection Module**. The **Surge Protection Module** is designed for the electrical standard used within the cabling loop and IPM.

The **Power Supply Module** supplies power to the gauges in accordance with the electrical standard used by the gauge manufacturer.

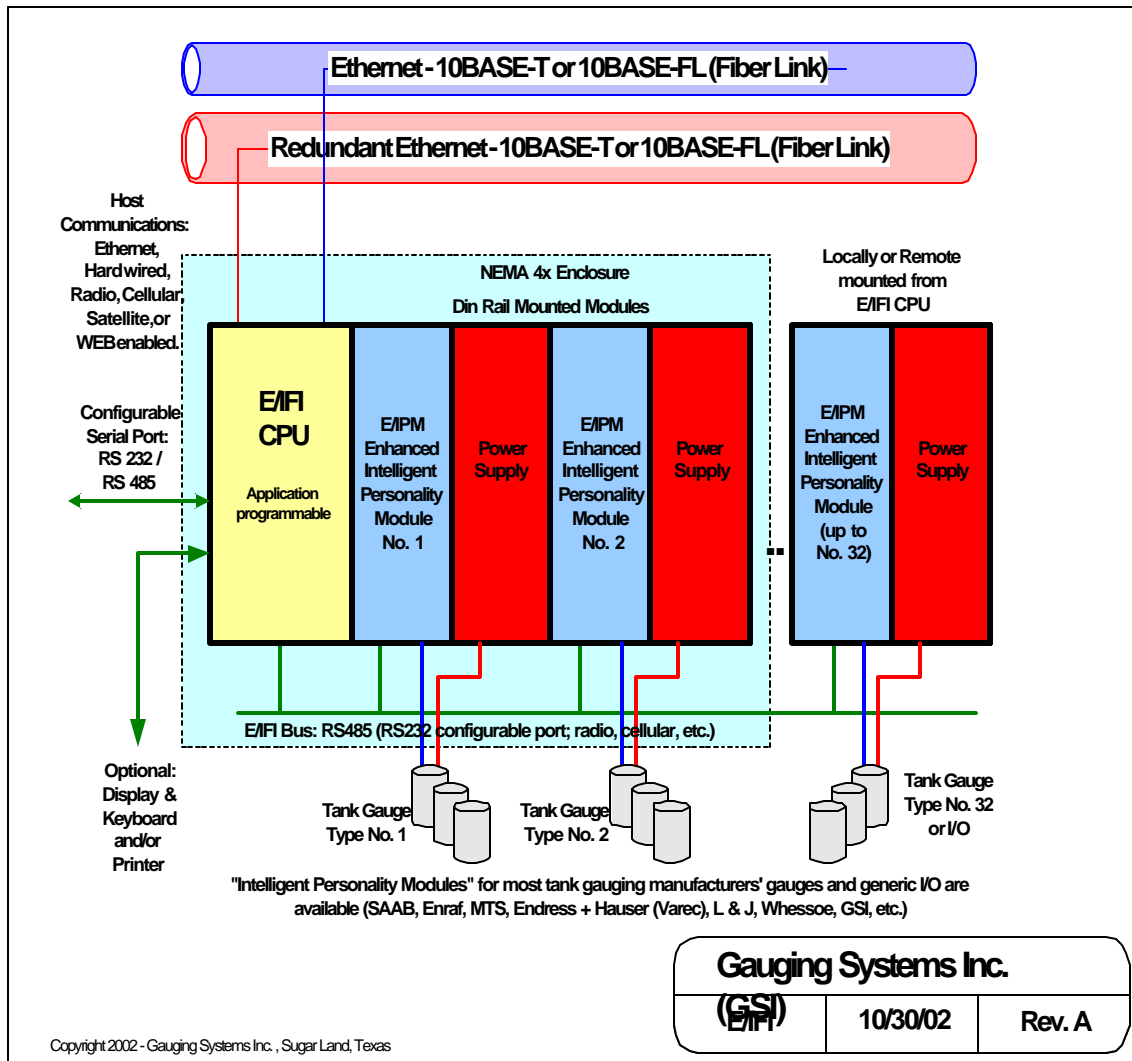

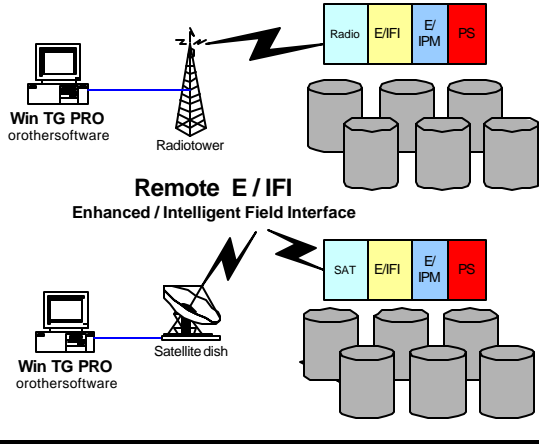
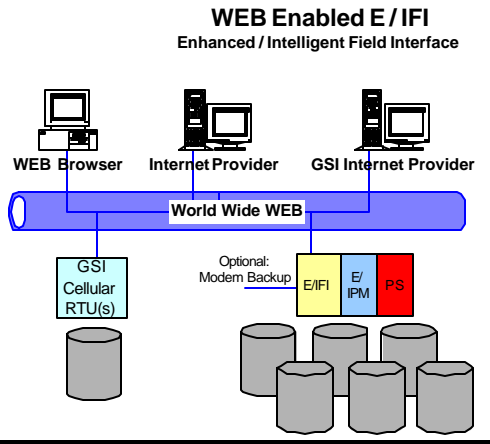
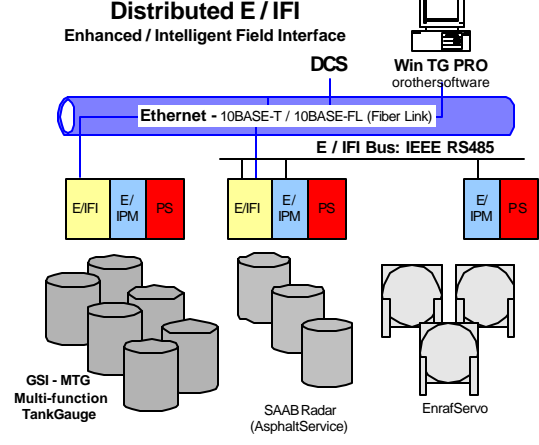
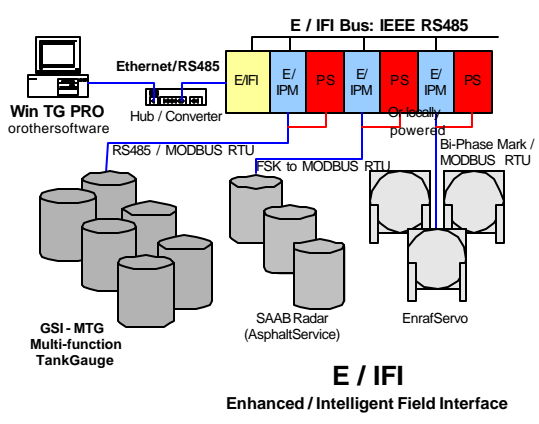

Functionality:

The E/IFI software in normal operation is designed to poll all tanks continuously. This capability is a function of the IPM. It is downloaded and stores in non-volatile memory all tanks that have been assigned to that cabling loop. The **Intelligent Personality Module** refreshes and holds the data from those tanks on a continual basis and passes the data to the **CPU Module** upon request or scheduled intervals.

The speed of the requested data from the **Intelligent Personality Module** to the **CPU Module** is extremely fast as block data in comparison with the polling of most gauge technology by the **Intelligent Personality Module**. The **CPU Module** can also request diagnostic registers or single data point registers from the **Intelligent Personality Module**. In addition, a straight through mode of communications to a gauge is provided for configuration and diagnostics with some serial protocols.

The data is received by the **CPU Module** where it can be reformatted or translated into another protocol, etc. The **CPU Module** then transmits the data upon request or programmed intervals to the Host or HMI. The means of cabling topologies or communications include: Hardwire, Ethernet (10BASE-FL Fiber Link or 10BASE-T), Spread Spectrum Radio, BlueTooth, Cellular, Satellite, or WEB enabled.

Reversed Functionality:

The **Intelligent Personality Module** when used as a stand-alone device or with a power supply has the unique capability to be used in a reversed manner.

Instead of communicating with the **CPU Module** over the RS 485 bus, the RS 485 port is used to communicate with the gauge technology. Any gauge technology using an IEEE RS 485 electrical standard and MODBUS RTU protocol can be used to replace the existing gauge technology. This includes: MTG "Multi-function Tank Gauge", CAP "Capacitance Accurate Probe", etc.

The field port on the **Intelligent Personality Module** is then used to communicate to the host system using the existing electrical standard and protocol, i.e., Bi-phase Mark, DDA, Tankway, GPE 31423/31422, Mark-Space, etc.

Note: If you install new gauge technology that offers more data variables than the gauge technology being replaced, you will be limited to the data variables of the existing gauge technology. Example: A mechanical gauge with only level and temperature being replaced by a MTG would only provide level and temperature data variables.

Reversed Functionality will allow the testing of new gauge technology, replacing problem equipment, or slowly retrofitting in newer technology until full data communications is economically justified.

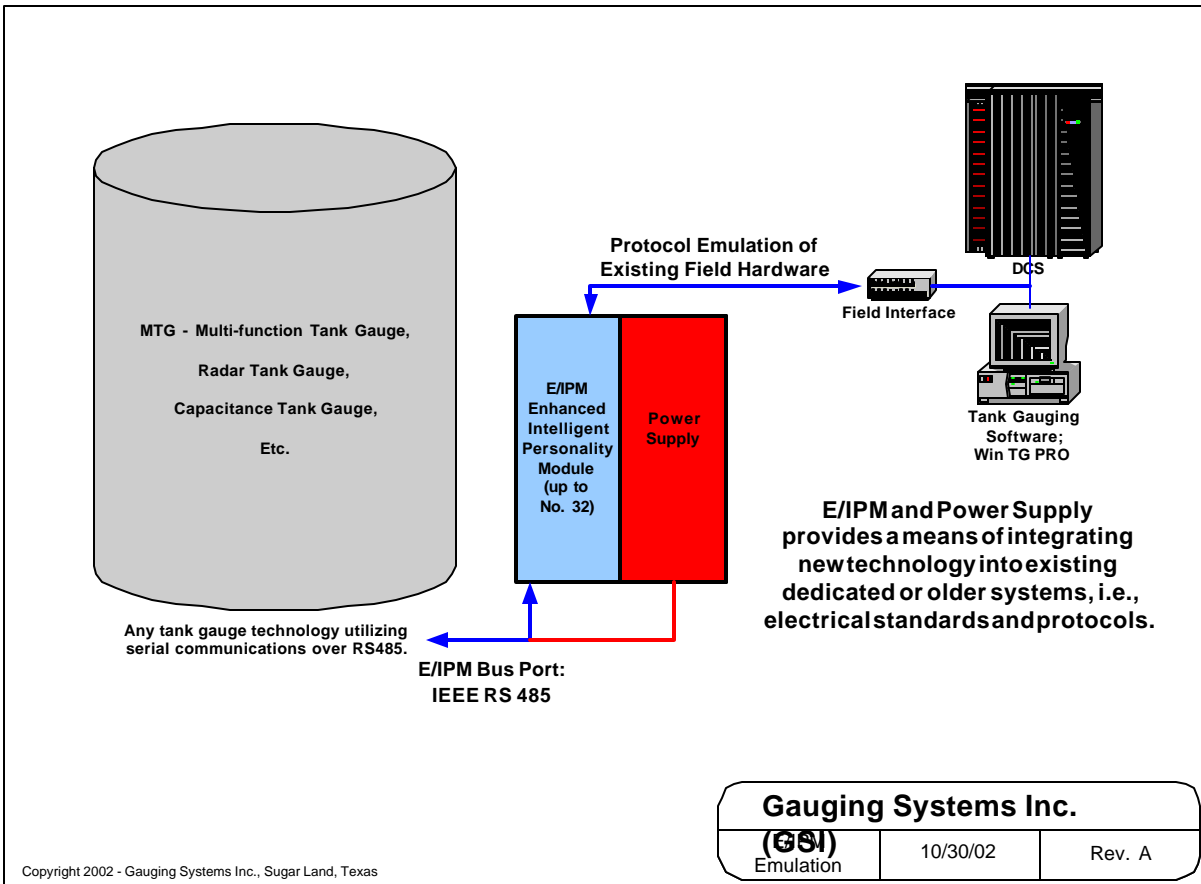

Diagnositics:

We designed an interface that is quickly serviced by using the diagnostic indicators on each module. Each **Intelligent Personality Module** has diagnostic LED's to indicate problems, such as: No power, No communications to field device, No communications with CPU, Bus error, Surge Protection fault, etc. Thus, providing an indication of where the problem is located and how to trouble shoot the problem. The modules are pullout and plug-in replaceable.

The E/IFI is provided with diagnostic software on the **CPU Module**. It provides diagnostic information to the HMI when problems occur, thus, indicating when service is needed. Based upon the diagnostic capabilities of each gauge manufacturer (electrical standard & protocol), the E/IFI will pass the manufacturers diagnostic data to the HMI.

Enhanced / Intelligent Field Interface Options:

The CPU Module is programmable for custom applications, such as transfer tickets, leak detection, etc. The unit can optionally be provided with a LCD display and/or a ribbon printer. In addition, drivers can be supplied for protocol conversion, host device communications, etc.

Specifications:

Enclosure:	NEMA 4x Weather Proof
Power Requirement:	110 Vac (Standard), 220 Vac
Module Form factor:	Din Rail Mounted within enclosure
CPU Module:	2MB - 8MB of non-volatile (Flash) memory, 16MB - 64MB RAM (Same as GSI-1555 E/TGI CPU Board)
CPU Communication Ports:	Two RS 485 / RS 232 configurable, Two Ethernet 10BASE-T or 10BASE-FL Fiber Link
CPU Communications:	MODBUS RTU, MODBUS encapsulated TCP/IP, MODBUS ASCII, TLS-350, etc.
Intelligent Personality Module:	Maximum of 32 IPM's per E/IFI, Maximum of 50 addresses per IPM (Dependent upon electrical standard and protocol of the gauge loop devices. Maintenance considerations should also be given to loop size).
IPM ports:	One RS 485 (Host), One Gauge Loop port based upon the IPM's electrical standard and protocol. Optional: Fiber Port for field diagnostics and CPU communications.
IPM Power (Reverse Functionality):	Powered by existing field bus (gauge loop), 9 - 70 Vdc dependent upon electrical standard and protocol of the gauge loop devices.

GSI - E/IFI “Enhanced Intelligent Field Interface”

Ordering Information

Model Number: GSI - E/IFI – A – B – C – D – E – F – G – H

A = Field Input - E/IPM Module Electrical Standard & Protocol

IEEE RS485, 24Vdc, Modbus RTU protocol	=	MBR
(GSI, Enraf, MTS, SAAB, E + H, L & J - Specify)		
DDA - 24Vdc, MTS Magnetostrictive Probe	=	DDA
Bi-phase Mark - 110Vac, Enraf	=	BPM
Tankway - 39 Vdc-70 Vdc, L & J Engineering	=	TWY
31422 / 31423 - 48Vac, GPE / L & J Engineering	=	GPE
Frequency Shift Key , 110 Vac, SAAB Radar	=	FSK
1800 Mark-Space, 48 Vdc, Varec / Endress + Hauser	=	1800
1900 Mark-Space, 48 Vdc, Varec / Endress + Hauser	=	1900
Other protocols, please specify..		

B = Power Distribution

0	=	Field Devices Powered Locally
1	=	Field Devices and E/IFI Powered by Bus
2	=	Field Devices Powered by E/IFI (Standard)
3	=	Field Devices Powered by E/IFI Solar Option

C = Power (power source available to the E/IFI, example = 110Vac)

D = Host Output from CPU Module

A	=	RS 485, Modbus RTU Protocol (Configurable Register Map)
B	=	RS 485, ASCII Protocol (See GSI for standard & custom protocols)
C	=	RS 485/RS 232 to Radio (Spread Spectrum)
D	=	RS 485/RS 232 to Satellite (Low earth orbiting)
F	=	RS 485/RS 232 to Cellular (Modem)
G	=	RS 485/RS 232 to Phone (Modem)
H	=	10BASE-T Ethernet, Modbus encapsulated TCP/IP
I	=	10BASE-FL “Fiber Link” Ethernet Output, Modbus encapsulated TCP/IP
J	=	TLS-350 Protocol via RS 485/RS 232 or Ethernet 10BASE-FL

E = Surge Protection and/or I.S. Barriers

4	=	Surge Protection
5	=	IS Barriers
6	=	Surge Protection and IS Barriers

F = Enclosure

K	=	NEMA 4x, Water Proof and Rain Tight (E/IFI Standard)
---	---	--

G = Display Options

8	=	LCD, 4 lines x 20 Characters
9	=	VGA LCD Display

H = Options

L	=	I/O Configuration
M	=	I/O Configuration
N	=	Reverse Functionality - IPM in NEMA 7 Enclosure
P	=	Ribbon Printer
Q	=	WEB enabled device, browser software
R	=	Custom Software

If you have any questions, please contact Gauging Systems Inc.